

# Engineering the Future of Facility Stewardship

The National Institute of Building Sciences (NIBS) Facility Operations and Maintenance Council (FMOC) empowers facility managers to optimize building performance, ensure occupant safety, and extend asset longevity.

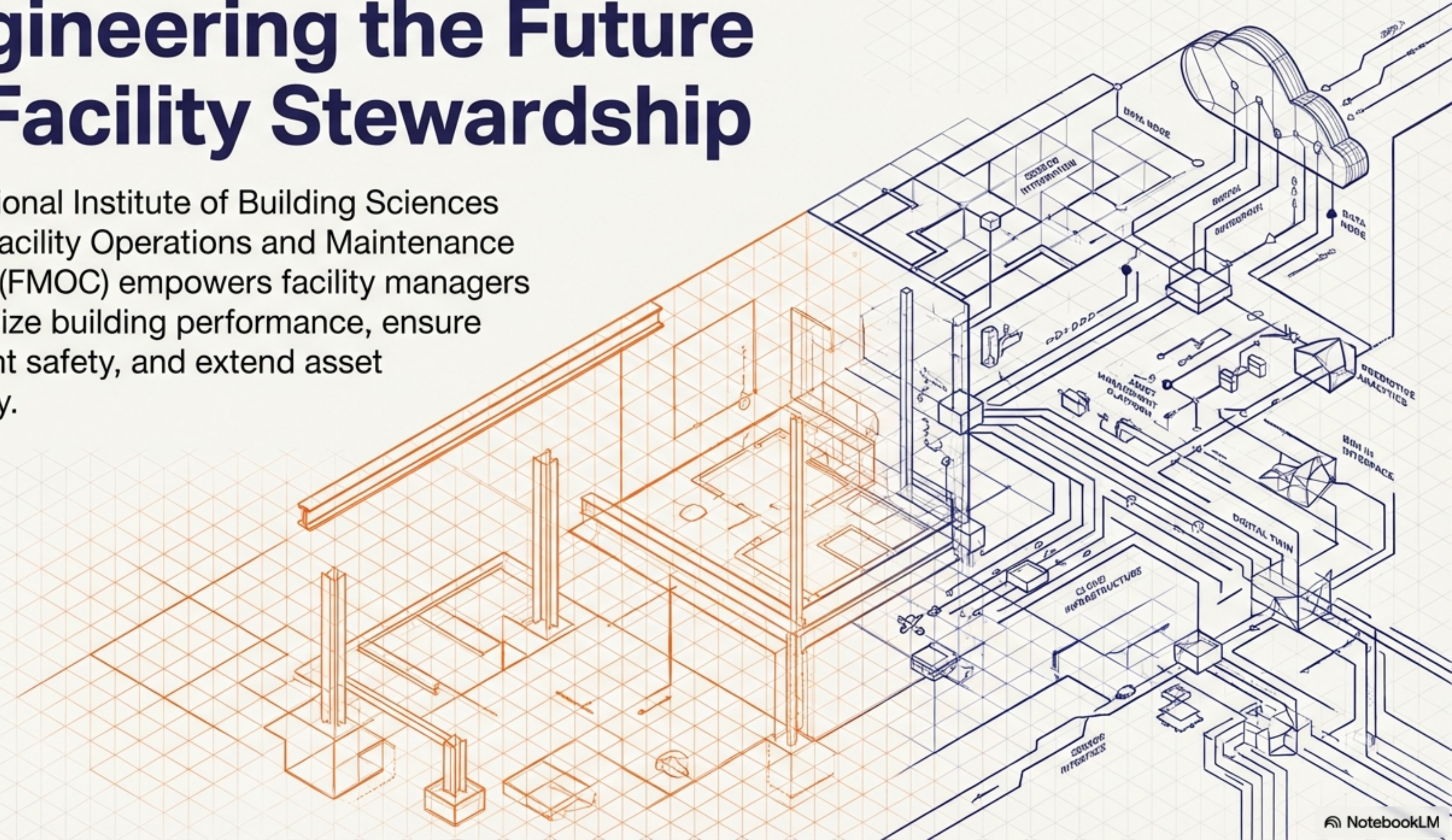



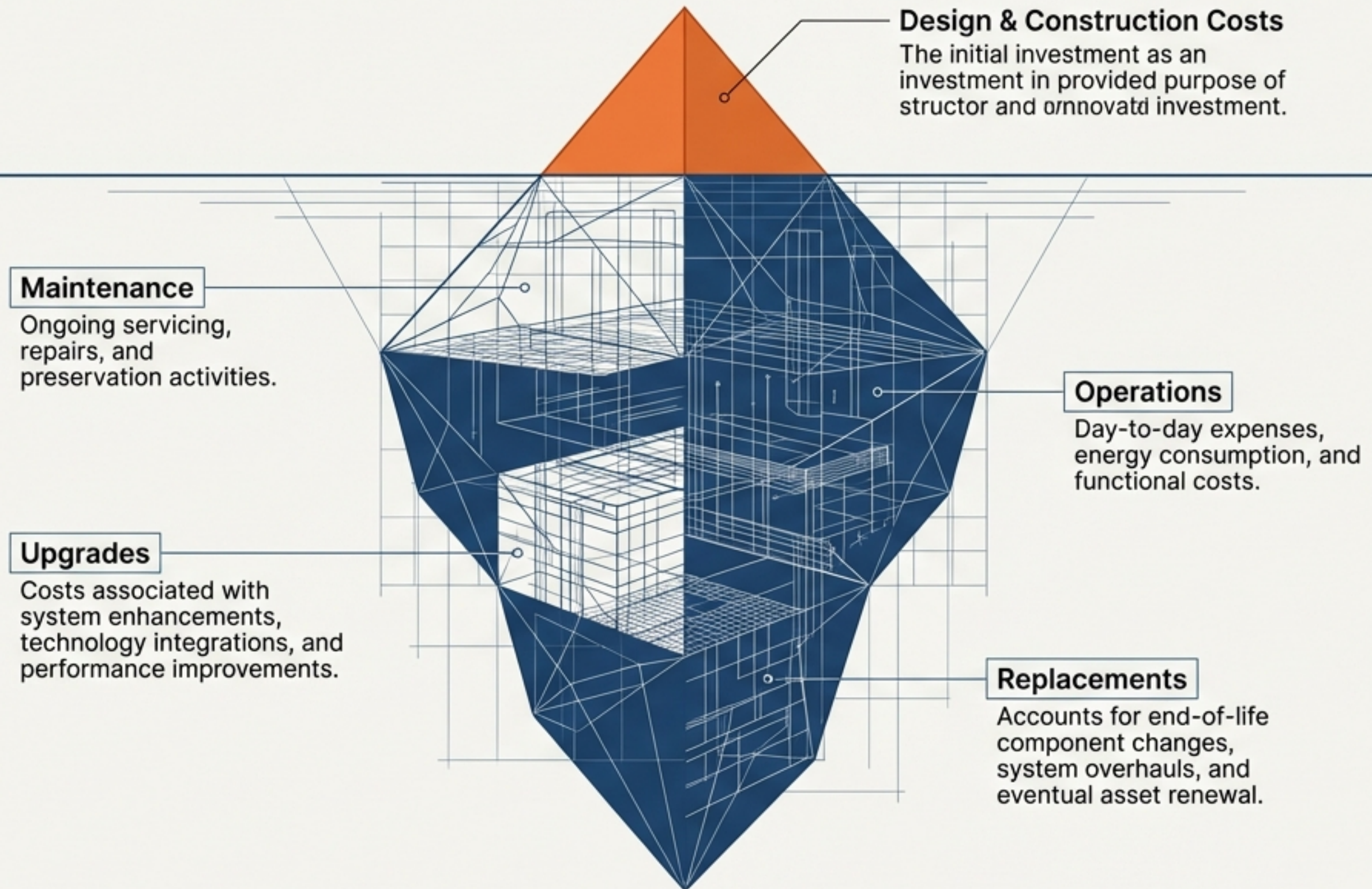

# The True Cost of an Asset Resides Below the Surface

Understanding the asset's total life cycle and cost of ownership allows facility managers to plan for maintenance and eventual replacement, avoiding unexpected disruptions and minimizing expenses over the asset's lifetime.

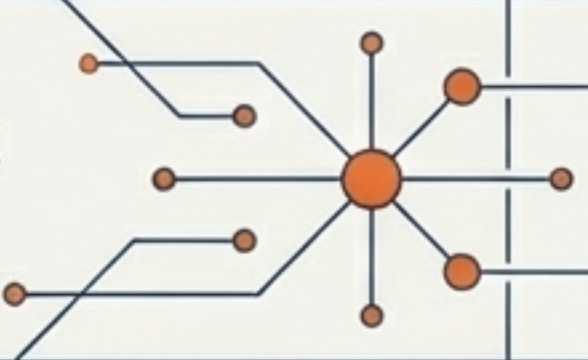

# Shifting the Asset Management Paradigm

	Traditional Approach	<b>FMOC-Guided Approach</b>
Data Integration	Siloed and late-stage	<b>Integrated from the earliest planning stages</b> 
Handover Quality	Paper-based and incomplete	<b>Standardized, accurate, and comprehensive documentation</b> 
Operational Posture	Reactive troubleshooting	<b>Proactive planning and predictive maintenance</b> 
Financial Focus	Initial capital cost	<b>Total Cost of Ownership (TCO) and sustainable operations</b> 

# Upstream Integration Drives Downstream Performance

Capturing comprehensive design and construction information from the earliest planning stages.

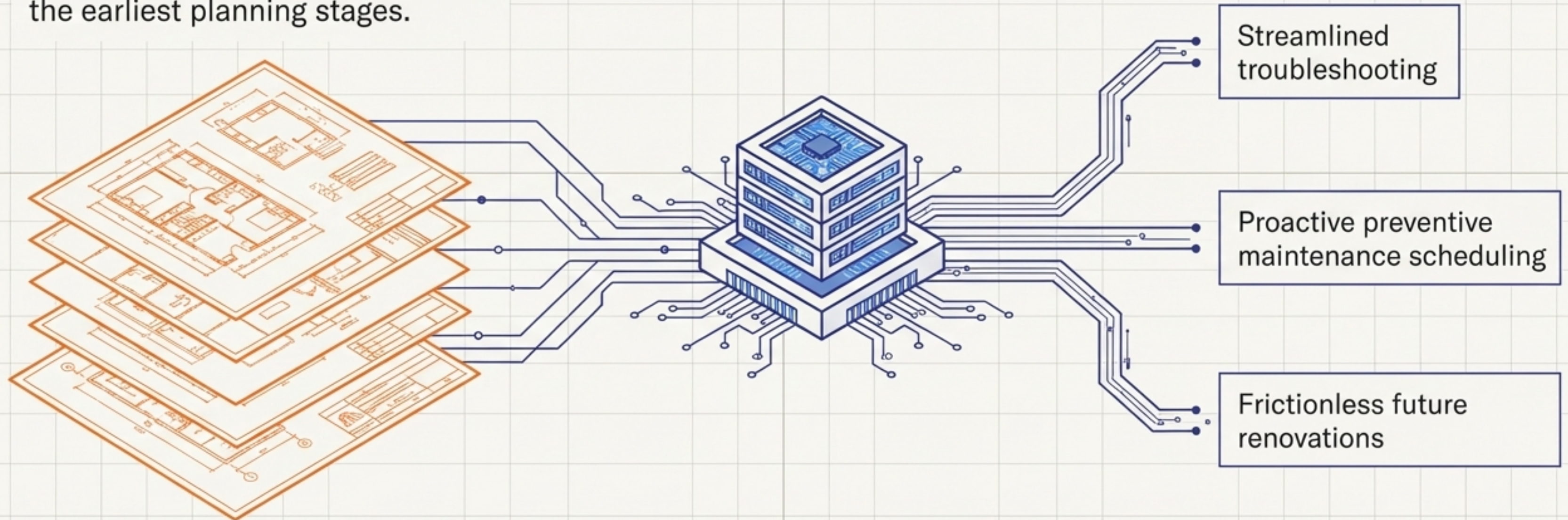

# Bridging the Critical Gap Between Construction and Operations

Construction Teams

Facility Managers

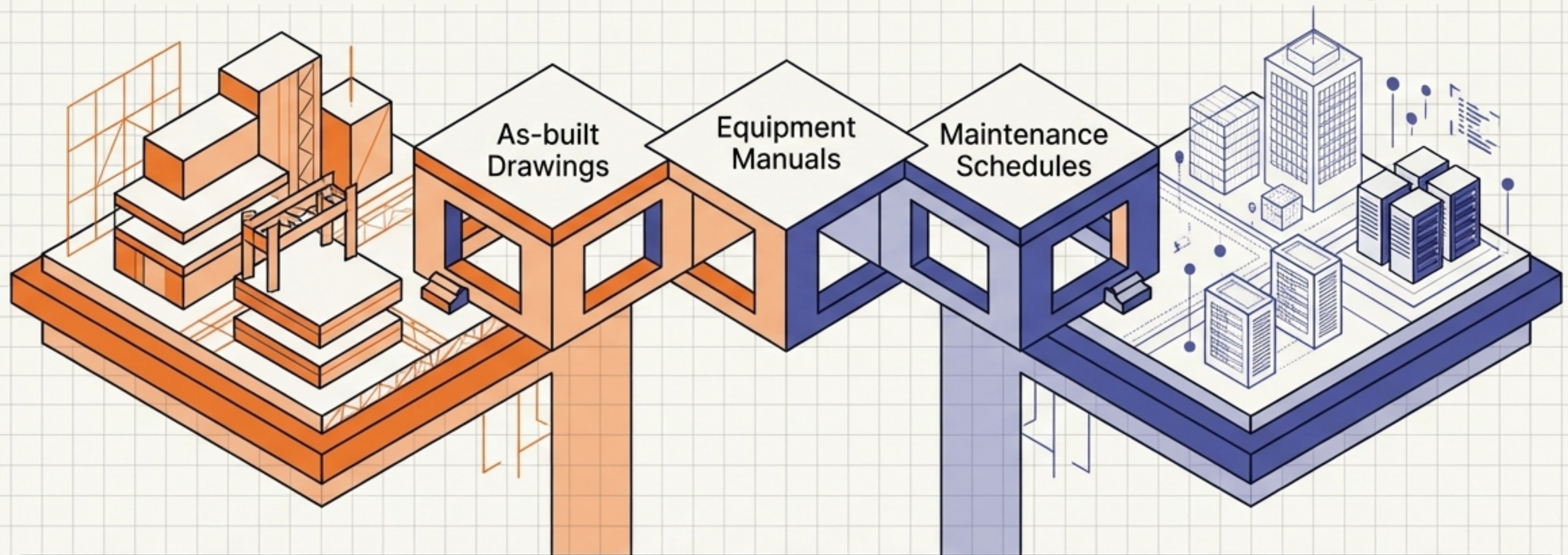

A smooth transition requires complete and accurate handover documentation to establish a **clear record of assets**. This equips managers with the tools necessary for effective long-term stewardship.

# Standardizing the Universal Language of Facility Data

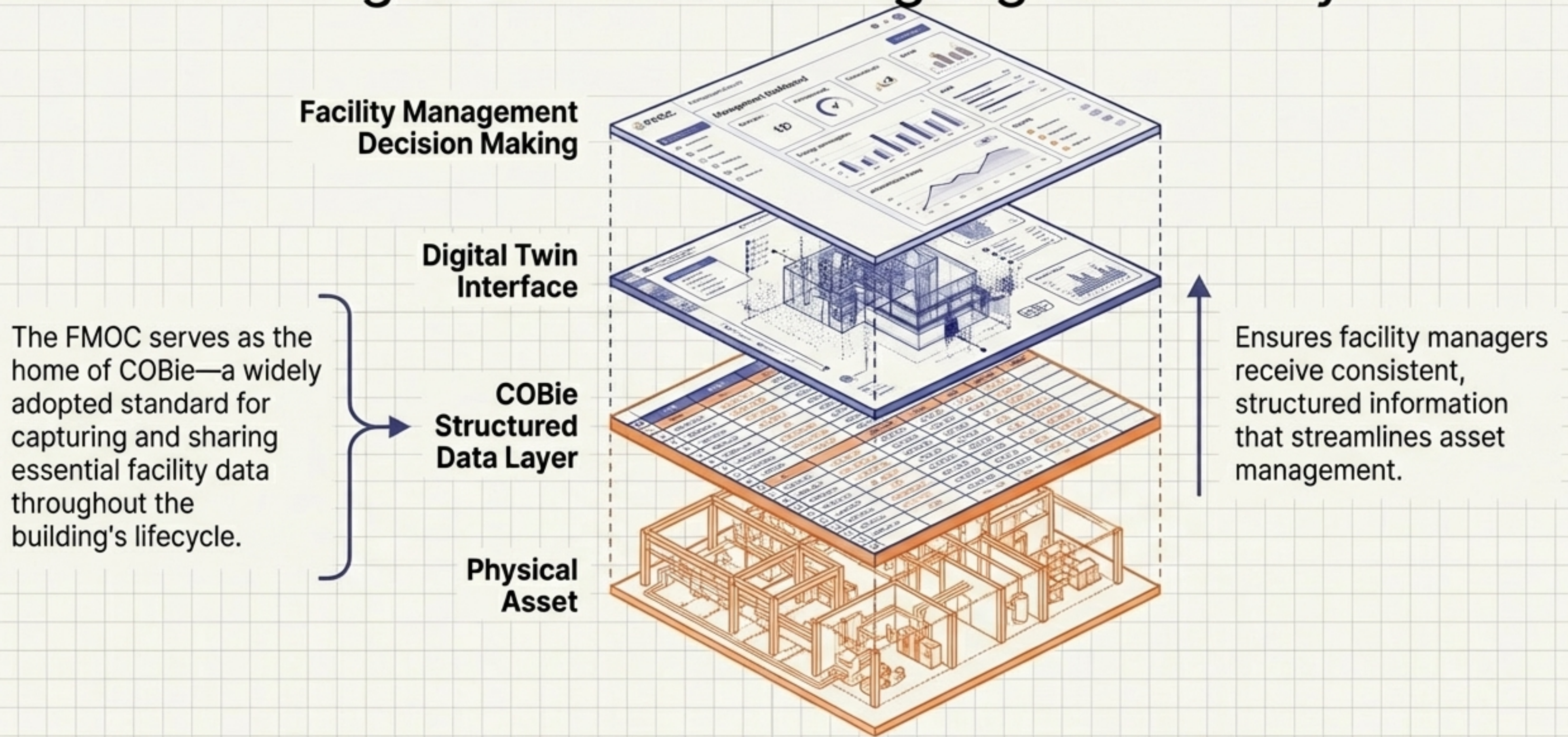

# The Digital Twin as an Operational Command Center

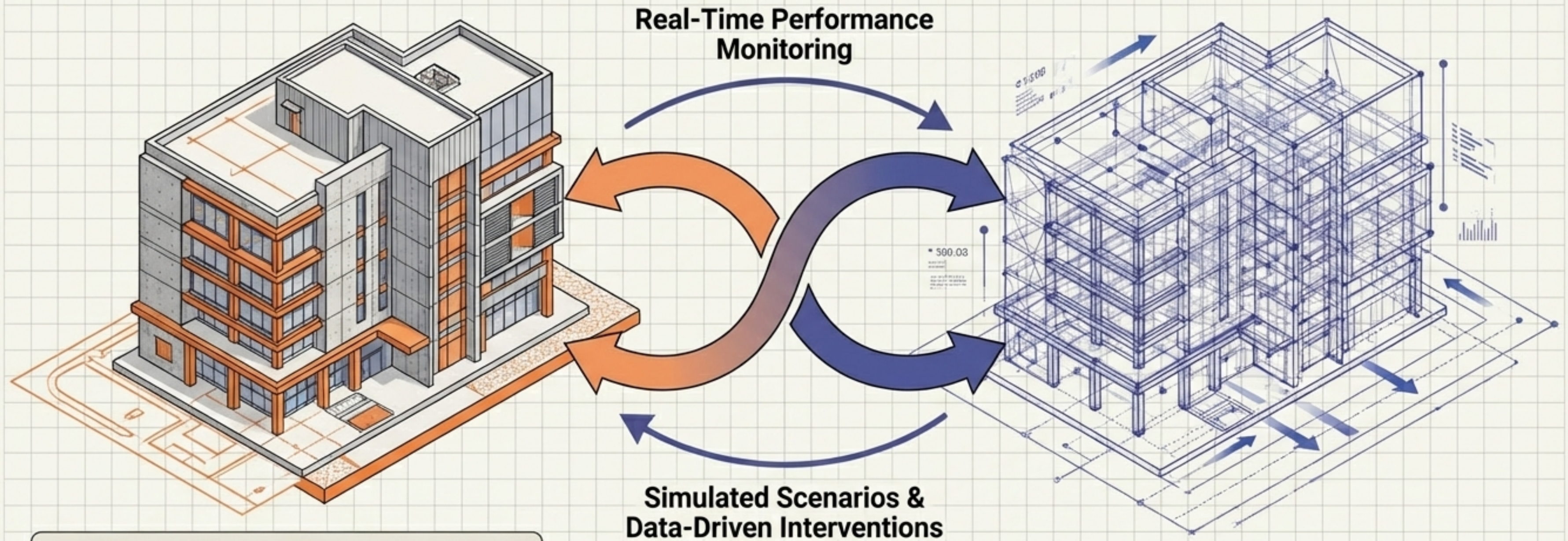

The FMOC actively aids in developing and utilizing **digital twins** to mirror physical systems, enhancing operational efficiency and long-term asset stewardship.

# The Golden Thread of Continuous Facility Data

## Design Phase

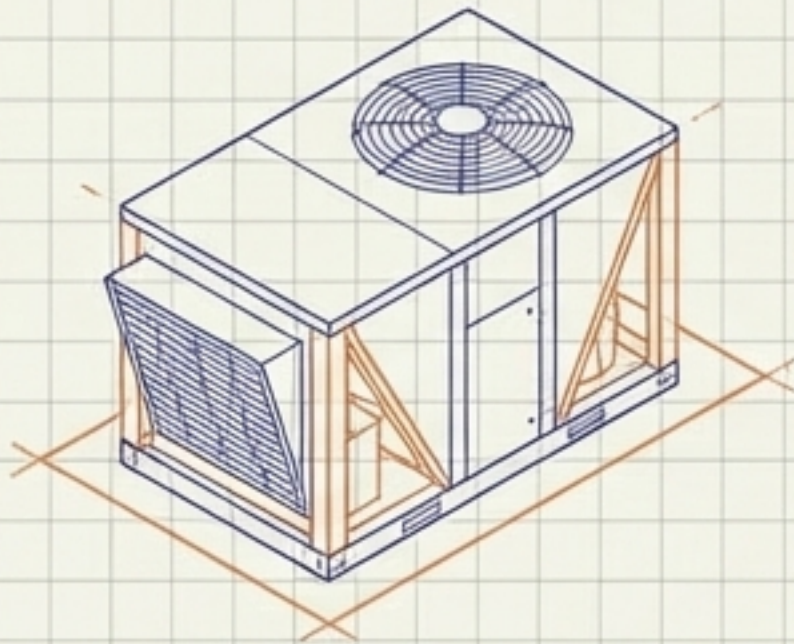

## Handover (COBie)

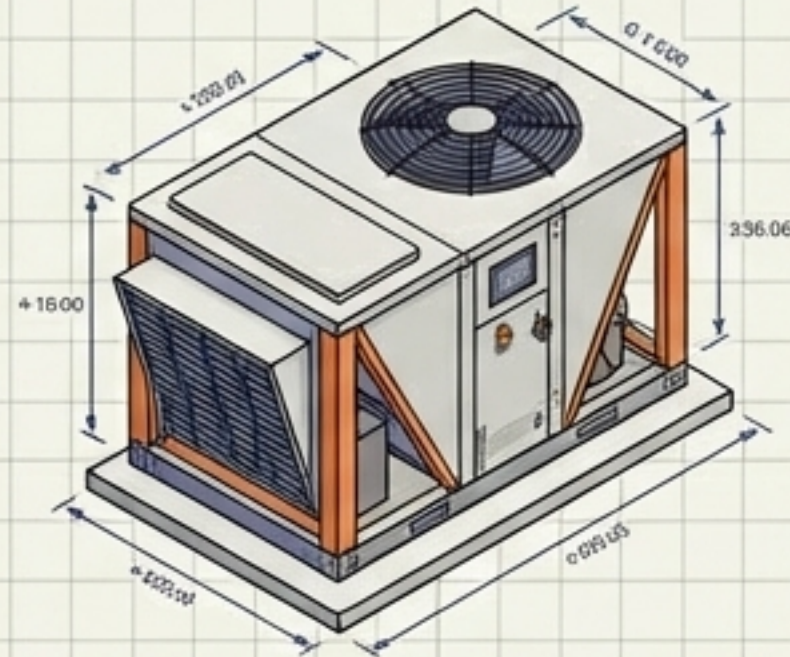

## Digital Twin

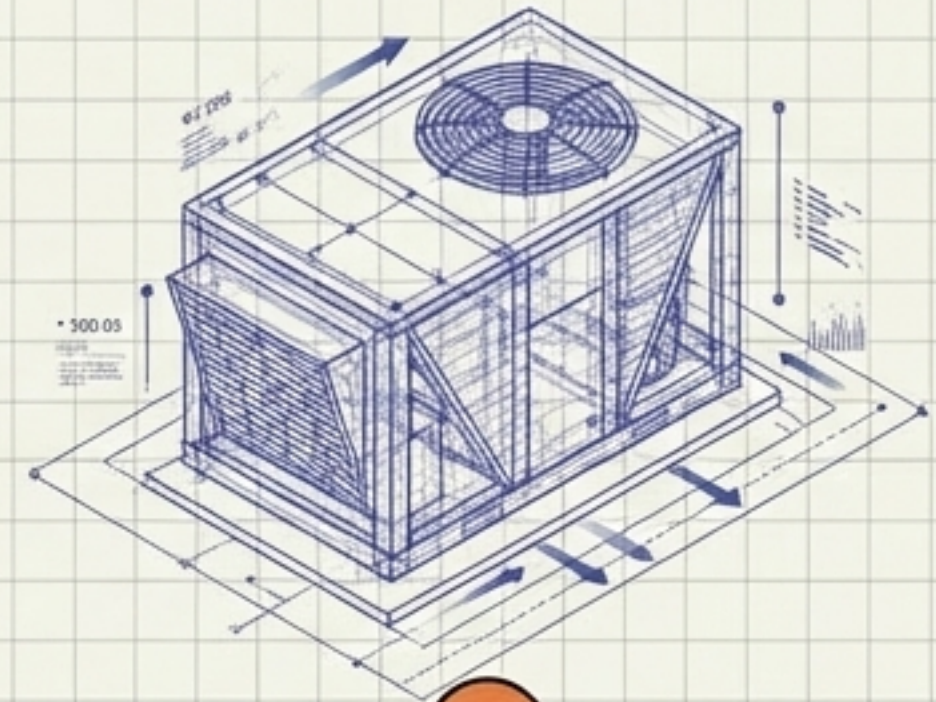

Thermal Capacity  
Requirements

Manufacturer Serial Number  
& Maintenance Schedule

Live Vibration Data  
& Predictive Alerts

The **exact same operational data** originates in design, is packaged via COBie during handover, and is activated in the Digital Twin to ultimately optimize the **Total Cost of Ownership**.

# Maximizing Value Through Holistic Stewardship

## Sustainable Operations

Maximizing efficiency while minimizing unforeseen expenses.

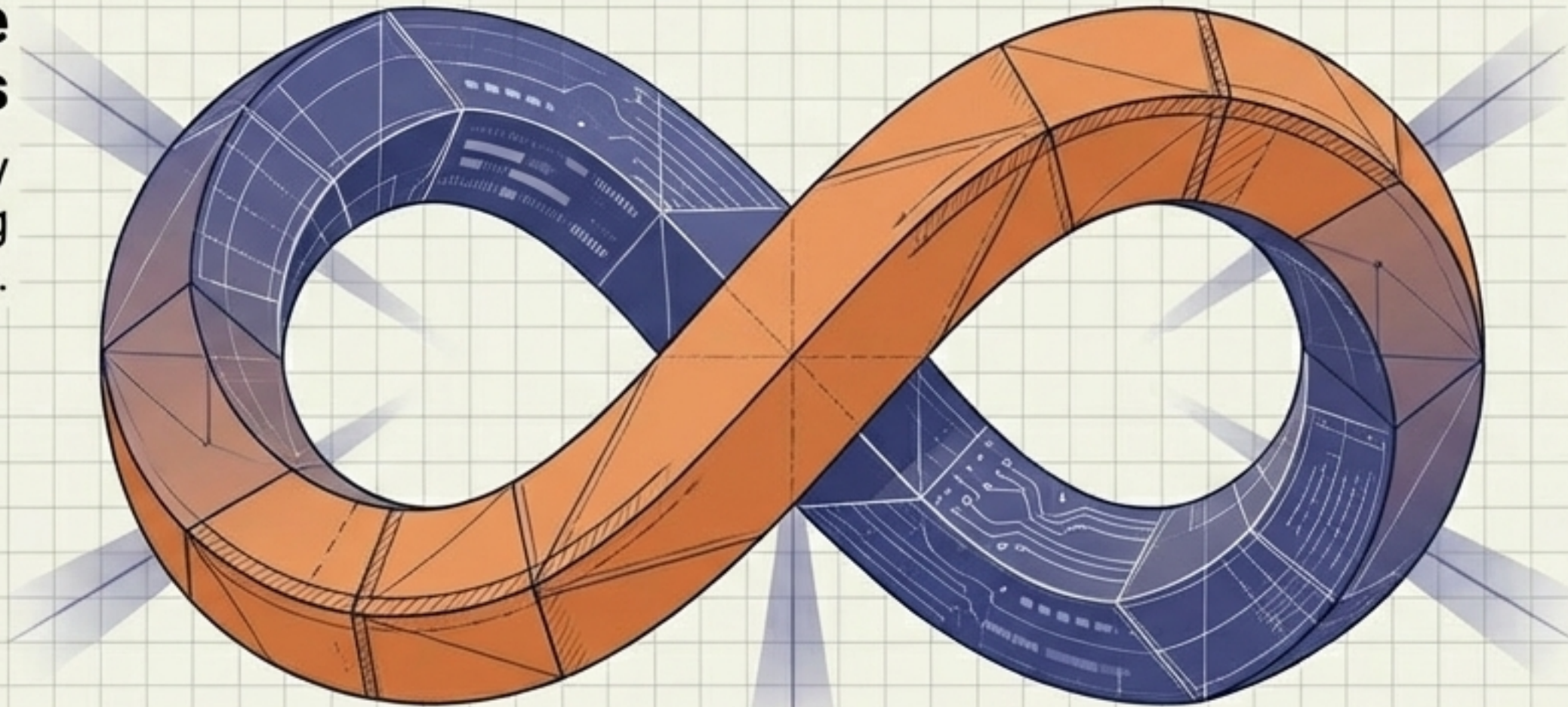

## Collaborative Best Practices

Staying abreast of evolving industry standards and technologies.

## Holistic Perspective

Considering the entire asset life cycle.

Equipping facility managers with the knowledge, standardized tools, and foresight necessary for the lifetime stewardship of the built environment.